

LM317L

3-Terminal Adjustable Regulator

General Description

The LM317L is an adjustable 3-terminal positive voltage regulator capable of supplying 100mA over a 1.2V to 37V output range. It is exceptionally easy to use and requires only two external resistors to set the output voltage. Further, both line and load regulation are better than standard fixed regulators. Also, the LM317L is available packaged in a standard TO-92 transistor package which is easy to use.

In addition to higher performance than fixed regulators, the LM317L offers full overload protection. Included on the chip are current limit, thermal overload protection and safe area protection. All overload protection circuitry remains fully functional even if the adjustment terminal is disconnected.

Normally, no capacitors are needed unless the device is situated more than 6 inches from the input filter capacitors in which case an input bypass is needed. An optional output capacitor can be added to improve transient response. The adjustment terminal can be bypassed to achieve very high ripple rejection ratios which are difficult to achieve with standard 3-terminal regulators.

Besides replacing fixed regulators, the LM317L is useful in a wide variety of other applications. Since the regulator is "floating" and sees only the input-to-output differential voltage, supplies of several hundred volts can be regulated as long as the maximum input-to-output differential is not exceeded.

Also, it makes an especially simple adjustable switching regulator, a programmable output regulator, or by connecting a fixed resistor between the adjustment and output, the LM317L can be used as a precision current regulator. Supplies with electronic shutdown can be achieved by clamping the adjustment terminal to ground which programs the output to 1.2V where most loads draw little current.

The LM317L is available in a standard TO-92 transistor package, the SO-8 package, and 6-Bump micro SMD package. The LM317L is rated for operation over a -25°C to 125°C range.

Features

- Adjustable output down to 1.2V
- Guaranteed 100 mA output current
- Line regulation typically 0.01%V
- Load regulation typically 0.1%
- Current limit constant with temperature
- Eliminates the need to stock many voltages
- Standard 3-lead transistor package
- 80 dB ripple rejection
- Available in TO-92, SO-8, or 6-Bump micro SMD package
- Output is short circuit protected
- See AN-1112 for micro SMD considerations

Connection Diagrams

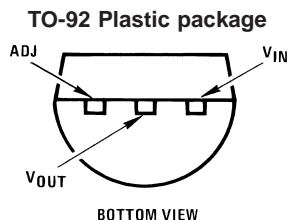

DS009064-4

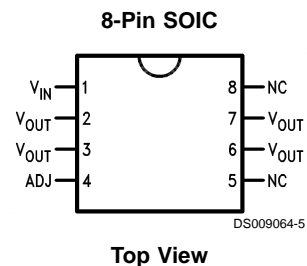

DS009064-5

Connection Diagrams (Continued)

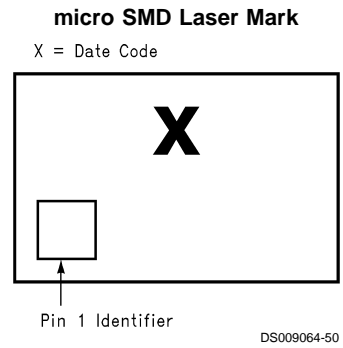
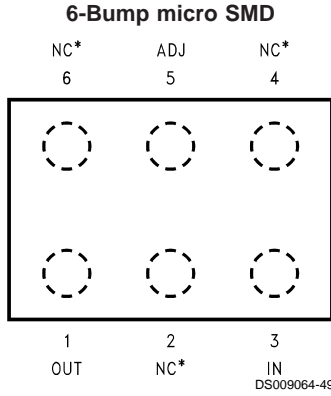

*NC = Not Internally connected.

**Top View
(Bump Side Down)**

Package	Part Number	Package Marking	Media Transport	NSC Drawing
TO-92	LM317LZ	LM317LZ	1.8k Units per Box	Z03A
8-Pin SOIC	LM317LM	LM317LM	Rails	M08A
6-Bump micro SMD	* LM317LIBP	—	250 Units Tape and Reel	BPA06HPA
	* LM317LIBPX	—	3k Units Tape and Reel	

Note: The micro SMD package marking is a single digit manufacturing Date Code only.

Absolute Maximum Ratings (Note 1)

If Military/Aerospace specified devices are required, please contact the National Semiconductor Sales Office/Distributors for availability and specifications.

Power Dissipation	Internally Limited
Input-Output Voltage Differential	40V
Operating Junction Temperature Range	-40°C to +125°C

Storage Temperature	-55°C to +150°C
Lead Temperature (Soldering, 4 seconds)	260°C
Output is Short Circuit Protected	
ESD rating to be determined.	

Electrical Characteristics (Note 2)

Parameter	Conditions	Min	Typ	Max	Units
Line Regulation	$T_J = 25^\circ\text{C}$, $3\text{V} \leq (V_{\text{IN}} - V_{\text{OUT}}) \leq 40\text{V}$, $I_L \leq 20\text{mA}$ (Note 3)		0.01	0.04	%/V
Load Regulation	$T_J = 25^\circ\text{C}$, $5\text{mA} \leq I_{\text{OUT}} \leq I_{\text{MAX}}$, (Note 3)		0.1	0.5	%
Thermal Regulation	$T_J = 25^\circ\text{C}$, 10ms Pulse		0.04	0.2	%/W
Adjustment Pin Current			50	100	μA
Adjustment Pin Current Change	$5\text{mA} \leq I_L \leq 100\text{mA}$ $3\text{V} \leq (V_{\text{IN}} - V_{\text{OUT}}) \leq 40\text{V}$, $P \leq 625\text{mW}$		0.2	5	μA
Reference Voltage	$3\text{V} \leq (V_{\text{IN}} - V_{\text{OUT}}) \leq 40\text{V}$, (Note 4) $5\text{mA} \leq I_{\text{OUT}} \leq 100\text{mA}$, $P \leq 625\text{mW}$	1.20	1.25	1.30	V
Line Regulation	$3\text{V} \leq (V_{\text{IN}} - V_{\text{OUT}}) \leq 40\text{V}$, $I_L \leq 20\text{mA}$ (Note 3)		0.02	0.07	%/V
Load Regulation	$5\text{mA} \leq I_{\text{OUT}} \leq 100\text{mA}$, (Note 3)		0.3	1.5	%
Temperature Stability	$T_{\text{MIN}} \leq T_J \leq T_{\text{MAX}}$		0.65		%
Minimum Load Current	$(V_{\text{IN}} - V_{\text{OUT}}) \leq 40\text{V}$ $3\text{V} \leq (V_{\text{IN}} - V_{\text{OUT}}) \leq 15\text{V}$		3.5 1.5	5 2.5	mA
Current Limit	$3\text{V} \leq (V_{\text{IN}} - V_{\text{OUT}}) \leq 13\text{V}$ $(V_{\text{IN}} - V_{\text{OUT}}) = 40\text{V}$	100 25	200 50	300 150	mA mA
Rms Output Noise, % of V_{OUT}	$T_J = 25^\circ\text{C}$, $10\text{Hz} \leq f \leq 10\text{kHz}$		0.003		%
Ripple Rejection Ratio	$V_{\text{OUT}} = 10\text{V}$, $f = 120\text{Hz}$, $C_{\text{ADJ}} = 0$ $C_{\text{ADJ}} = 10\mu\text{F}$	66	65 80		dB dB
Long-Term Stability	$T_J = 125^\circ\text{C}$, 1000 Hours		0.3	1	%
Thermal Resistance Junction to Ambient	Z Package 0.4" Leads Z Package 0.125 Leads SO-8 Package 6-Bump micro SMD		180 160 165 290		$^\circ\text{C/W}$ $^\circ\text{C/W}$ $^\circ\text{C/W}$ $^\circ\text{C/W}$
Thermal Rating of SO Package			165		$^\circ\text{C/W}$

Note 1: "Absolute Maximum Ratings" indicate limits beyond which damage to the device may occur. Operating Ratings indicate conditions for which the device is functional, but do not guarantee specific performance limits.

Note 2: Unless otherwise noted, these specifications apply: $-25^\circ\text{C} \leq T_J \leq 125^\circ\text{C}$ for the LM317L; $V_{\text{IN}} - V_{\text{OUT}} = 5\text{V}$ and $I_{\text{OUT}} = 40\text{mA}$. Although power dissipation is internally limited, these specifications are applicable for power dissipations up to 625 mW. I_{MAX} is 100 mA.

Note 3: Regulation is measured at constant junction temperature, using pulse testing with a low duty cycle. Changes in output voltage due to heating effects are covered under the specification for thermal regulation.

Note 4: Thermal resistance of the TO-92 package is 180°C/W junction to ambient with 0.4" leads from a PC board and 160°C/W junction to ambient with 0.125" lead length to PC board.

Typical Performance Characteristics (Output capacitor = 0μF unless otherwise noted.)

Load Regulation

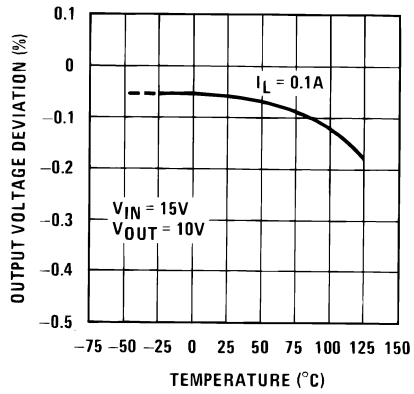

Current Limit

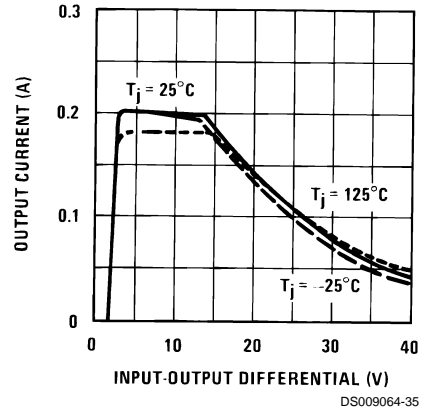

Adjustment Current

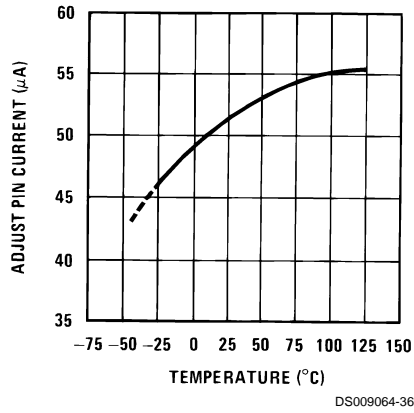

Dropout Voltage

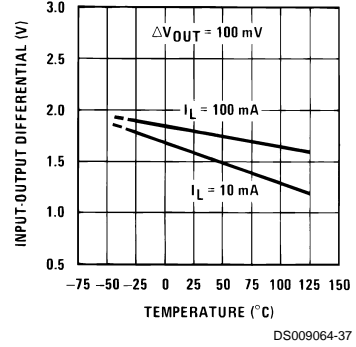

Reference Voltage Temperature Stability

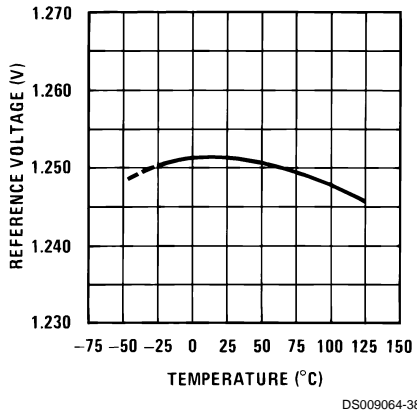

Minimum Operating Current

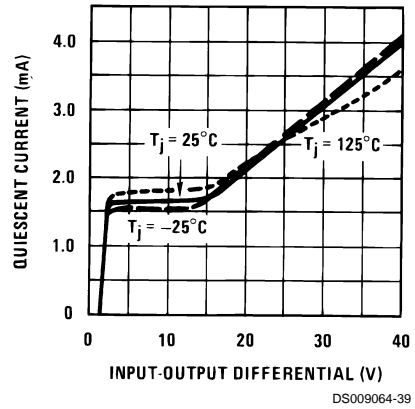

Typical Performance Characteristics (Output capacitor = 0 μ F unless otherwise noted.) (Continued)

Ripple Rejection

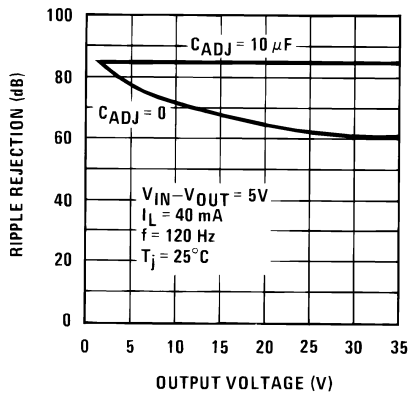

DS009064-40

Ripple Rejection

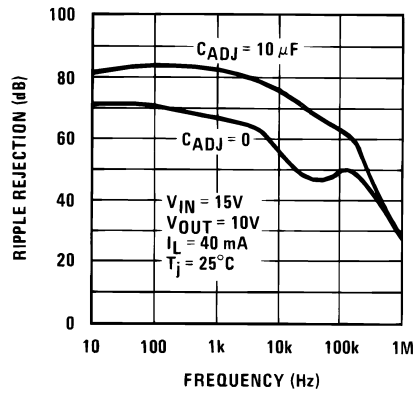

DS009064-41

Output Impedance

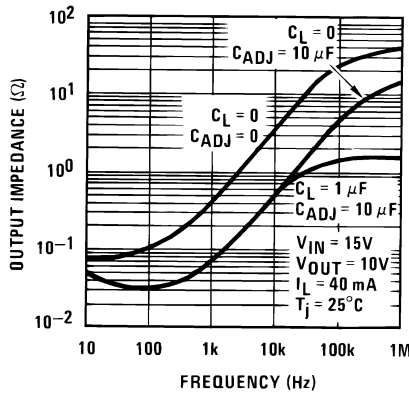

DS009064-42

Line Transient Response

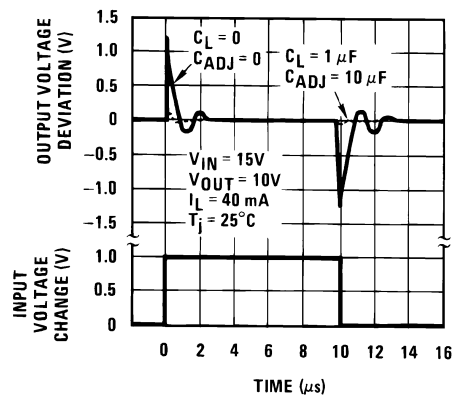

DS009064-43

Load Transient Response

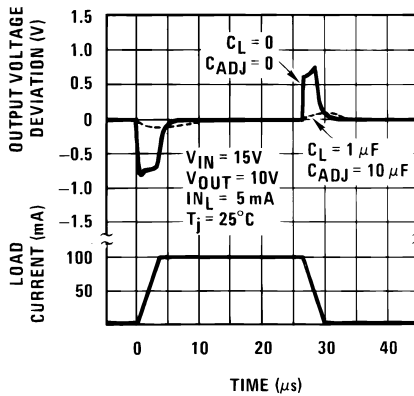

DS009064-44

Thermal Regulation

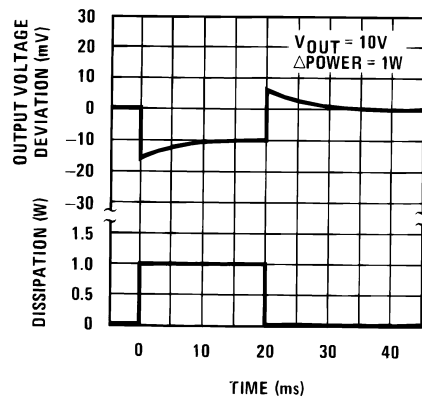

DS009064-45

Application Hints

In operation, the LM317L develops a nominal 1.25V reference voltage, V_{REF} , between the output and adjustment terminal. The reference voltage is impressed across program resistor R1 and, since the voltage is constant, a constant current I_1 then flows through the output set resistor R2, giving an output voltage of

$$V_{OUT} = V_{REF} \left(1 + \frac{R2}{R1} \right) + I_{ADJ}(R2)$$

Since the 100 μ A current from the adjustment terminal represents an error term, the LM317L was designed to minimize I_{ADJ} and make it very constant with line and load changes. To do this, all quiescent operating current is returned to the output establishing a minimum load current requirement. If there is insufficient load on the output, the output will rise.

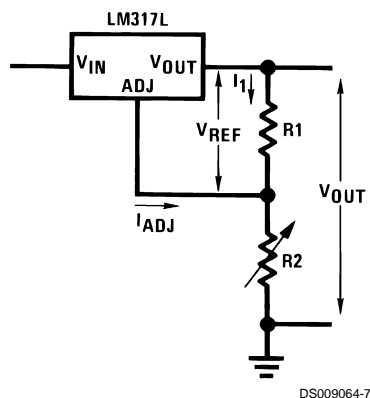

FIGURE 1.

External Capacitors

An input bypass capacitor is recommended in case the regulator is more than 6 inches away from the usual large filter capacitor. A 0.1 μ F disc or 1 μ F solid tantalum on the input is suitable input bypassing for almost all applications. The device is more sensitive to the absence of input bypassing when adjustment or output capacitors are used, but the above values will eliminate the possibility of problems.

The adjustment terminal can be bypassed to ground on the LM317L to improve ripple rejection and noise. This bypass capacitor prevents ripple and noise from being amplified as the output voltage is increased. With a 10 μ F bypass capacitor 80 dB ripple rejection is obtainable at any output level. Increases over 10 μ F do not appreciably improve the ripple rejection at frequencies above 120Hz. If the bypass capacitor is used, it is sometimes necessary to include protection diodes to prevent the capacitor from discharging through internal low current paths and damaging the device.

In general, the best type of capacitors to use is solid tantalum. *Solid tantalum capacitors have low impedance even at high frequencies.* Depending upon capacitor construction, it takes about 25 μ F in aluminum electrolytic to equal 1 μ F solid tantalum at high frequencies. Ceramic capacitors are also good at high frequencies; but some types have a large decrease in capacitance at frequencies around 0.5MHz. For this reason, a 0.01 μ F disc may seem to work better than a 0.1 μ F disc as a bypass.

Although the LM317L is stable with no output capacitors, like any feedback circuit, certain values of external capacitance can cause excessive ringing. This occurs with values be-

tween 500 pF and 5000 pF. A 1 μ F solid tantalum (or 25 μ F aluminum electrolytic) on the output swamps this effect and insures stability.

Load Regulation

The LM317L is capable of providing extremely good load regulation but a few precautions are needed to obtain maximum performance. The current set resistor connected between the adjustment terminal and the output terminal (usually 240 Ω) should be tied directly to the output of the regulator rather than near the load. This eliminates line drops from appearing effectively in series with the reference and degrading regulation. For example, a 15V regulator with 0.05 Ω resistance between the regulator and load will have a load regulation due to line resistance of 0.05 Ω x I_L . If the set resistor is connected near the load the effective line resistance will be 0.05 Ω (1 + R2/R1) or in this case, 11.5 times worse.

Figure 2 shows the effect of resistance between the regulator and 240 Ω set resistor.

With the TO-92 package, it is easy to minimize the resistance from the case to the set resistor, by using two separate leads to the output pin. The ground of R2 can be returned near the ground of the load to provide remote ground sensing and improve load regulation.

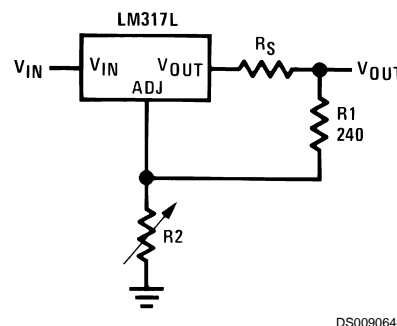

FIGURE 2. Regulator with Line Resistance in Output Lead

Thermal Regulation

When power is dissipated in an IC, a temperature gradient occurs across the IC chip affecting the individual IC circuit components. With an IC regulator, this gradient can be especially severe since power dissipation is large. Thermal regulation is the effect of these temperature gradients on output voltage (in percentage output change) per watt of power change in a specified time. Thermal regulation error is independent of electrical regulation or temperature coefficient, and occurs within 5ms to 50ms after a change in power dissipation. Thermal regulation depends on IC layout as well as electrical design. The thermal regulation of a voltage regulator is defined as the percentage change of V_{OUT} , per watt, within the first 10ms after a step of power is applied. The LM317L specification is 0.2%/W, maximum.

In the Thermal Regulation curve at the bottom of the Typical Performance Characteristics page, a typical LM317L's output changes only 7mV (or 0.07% of $V_{OUT} = -10V$) when a 1W pulse is applied for 10 ms. This performance is thus well inside the specification limit of 0.2%/W x 1W = 0.2% maximum. When the 1W pulse is ended, the thermal regulation again shows a 7 mV change as the gradients across the LM317L chip die out. Note that the load regulation error of about 14 mV (0.14%) is additional to the thermal regulation error.

Application Hints (Continued)

Protection Diodes

When external capacitors are used with *any* IC regulator it is sometimes necessary to add protection diodes to prevent the capacitors from discharging through low current points into the regulator. Most 10 μ F capacitors have low enough internal series resistance to deliver 20A spikes when shorted. Although the surge is short, there is enough energy to damage parts of the IC.

When an output capacitor is connected to a regulator and the input is shorted, the output capacitor will discharge into the output of the regulator. The discharge current depends on the value of the capacitor, the output voltage of the regulator, and the rate of decrease of V_{IN} . In the LM317L, this dis-

charge path is through a large junction that is able to sustain a 2A surge with no problem. This is not true of other types of positive regulators. For output capacitors of 25 μ F or less, the LM317L's ballast resistors and output structure limit the peak current to a low enough level so that there is no need to use a protection diode.

The bypass capacitor on the adjustment terminal can discharge through a low current junction. Discharge occurs when *either* the input or output is shorted. Internal to the LM317L is a 50 Ω resistor which limits the peak discharge current. No protection is needed for output voltages of 25V or less and 10 μ F capacitance. *Figure 3* shows an LM317L with protection diodes included for use with outputs greater than 25V and high values of output capacitance.

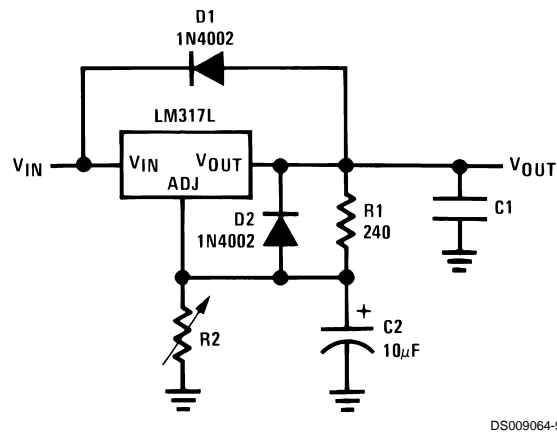

DS009064-9

$$V_{OUT} = 1.25V \left(1 + \frac{R2}{R1} \right) I_{ADJ} R2$$

D1 protects against C1
D2 protects against C2

FIGURE 3. Regulator with Protection Diodes

LM317L micro SMD Light Sensitivity

Exposing the LM317L micro SMD package to bright sunlight may cause the V_{REF} to drop. In a normal office environment of fluorescent lighting the output is not affected. The LM317

micro SMD does not sustain permanent damage from light exposure. Removing the light source will cause LM317L's V_{REF} to recover to the proper value.

Schematic Diagram

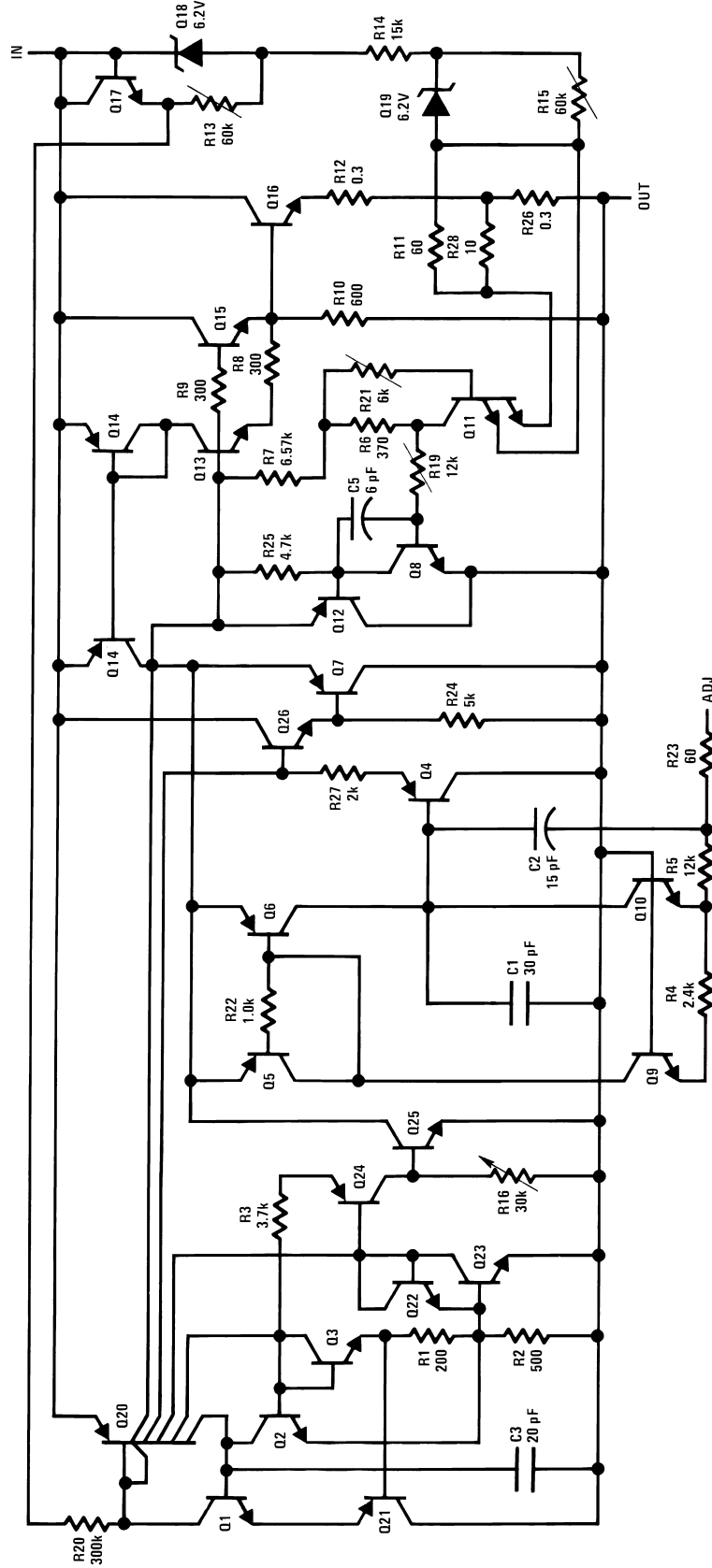

DS009064-10

Typical Applications

Digitally Selected Outputs

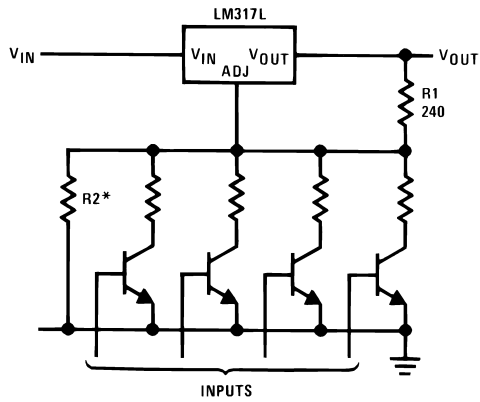

DS009064-11

*Sets maximum V_{OUT}

High Gain Amplifier

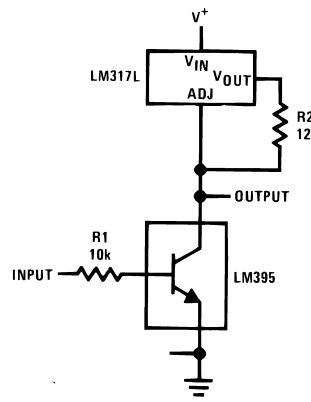

DS009064-12

Adjustable Current Limiter

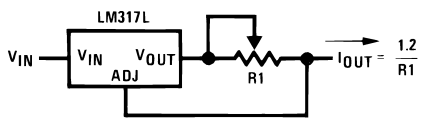

DS009064-13

$12 \leq R1 \leq 240$

Precision Current Limiter

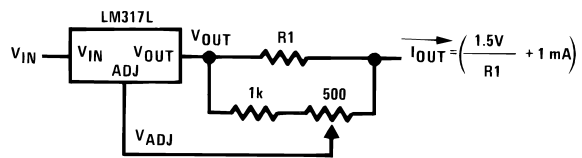

DS009064-14

Slow Turn-On 15V Regulator

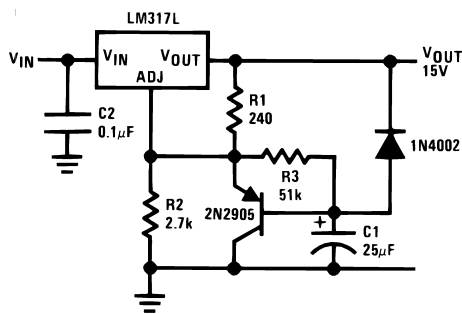

DS009064-15

Adjustable Regulator with Improved Ripple Rejection

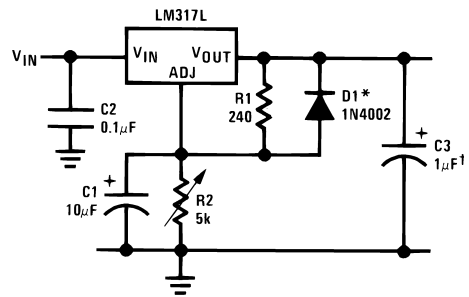

DS009064-16

†Solid tantalum

*Discharges C1 if output is shorted to ground

Typical Applications (Continued)

High Stability 10V Regulator

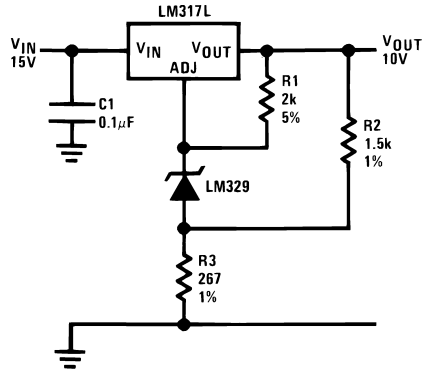

DS009064-17

Adjustable Regulator with Current Limiter

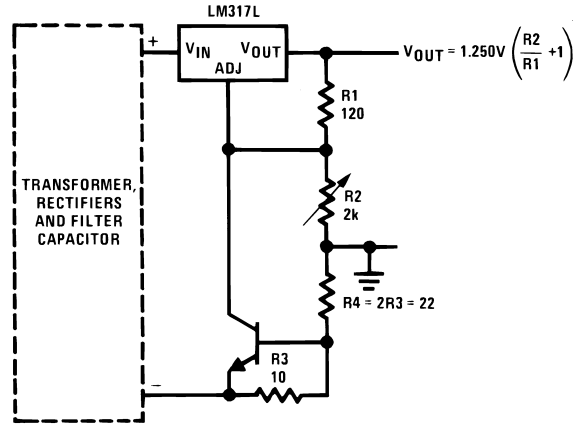

DS009064-18

Short circuit current is approximately $600 \text{ mV}/R3$, or 60mA (compared to LM317LZ's 200mA current limit).

At 25mA output only 3/4V of drop occurs in R3 and R4.

0V–30V Regulator

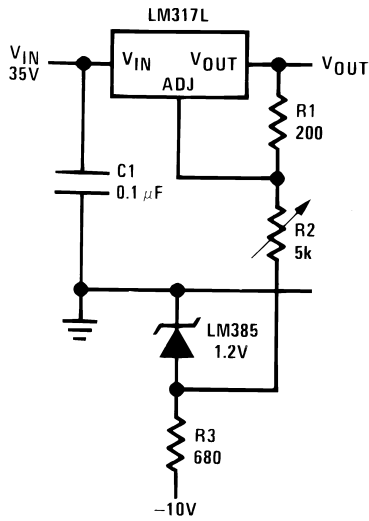

DS009064-19

Full output current not available at high input-output voltages

Regulator With 15mA Short Circuit Current

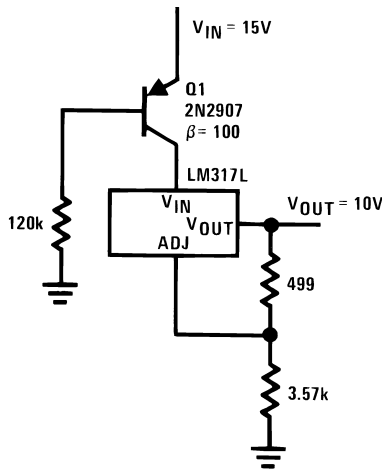

DS009064-20

Power Follower

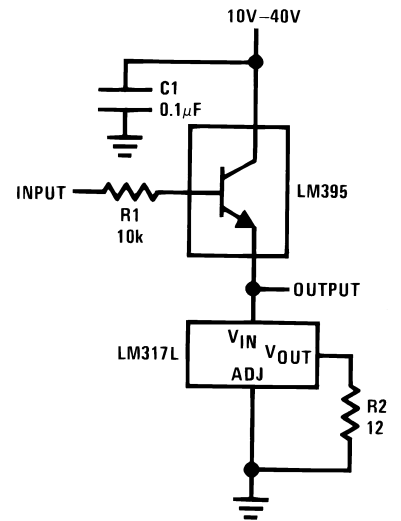

DS009064-21

Adjusting Multiple On-Card Regulators with Single Control*

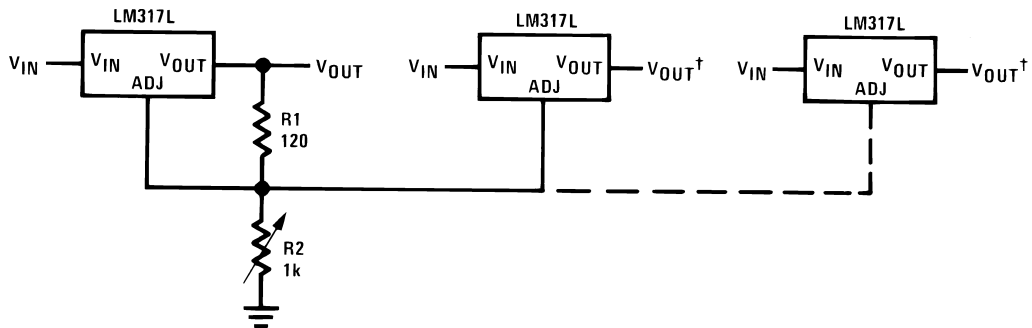

DS009064-22

*All outputs within $\pm 100\text{mV}$

†Minimum load -5mA

Typical Applications (Continued)

100mA Current Regulator

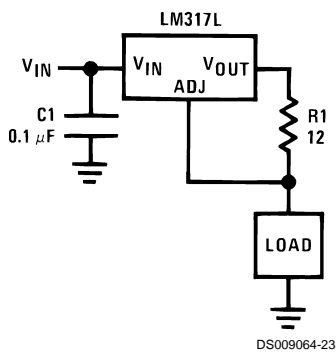

1.2V–12V Regulator with Minimum Program Current

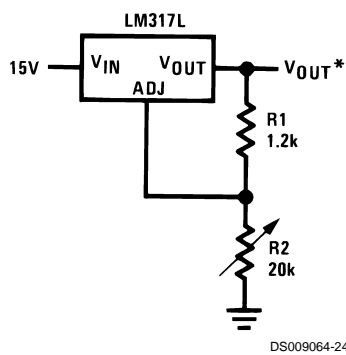

*Minimum load current ≈ 2 mA

50mA Constant Current Battery Charger for Nickel-Cadmium Batteries

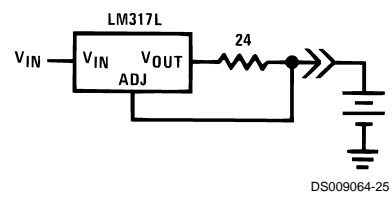

5V Logic Regulator with Electronic Shutdown*

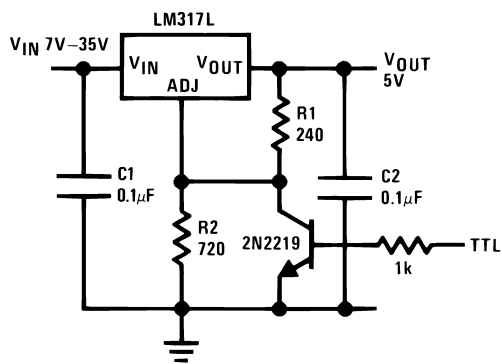

*Minimum output ≈ 1.2V

Current Limited 6V Charger

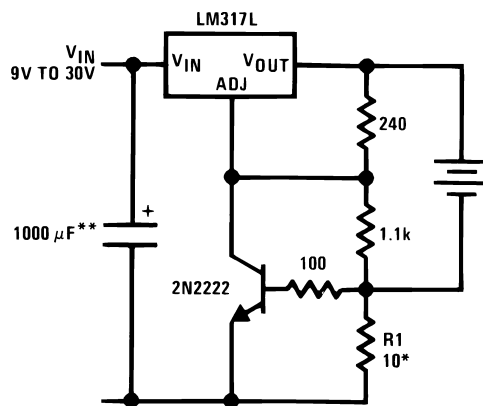

*Sets peak current, $I_{PEAK} = 0.6V/R1$

**1000μF is recommended to filter out any input transients.

Typical Applications (Continued)

Short Circuit Protected 80V Supply

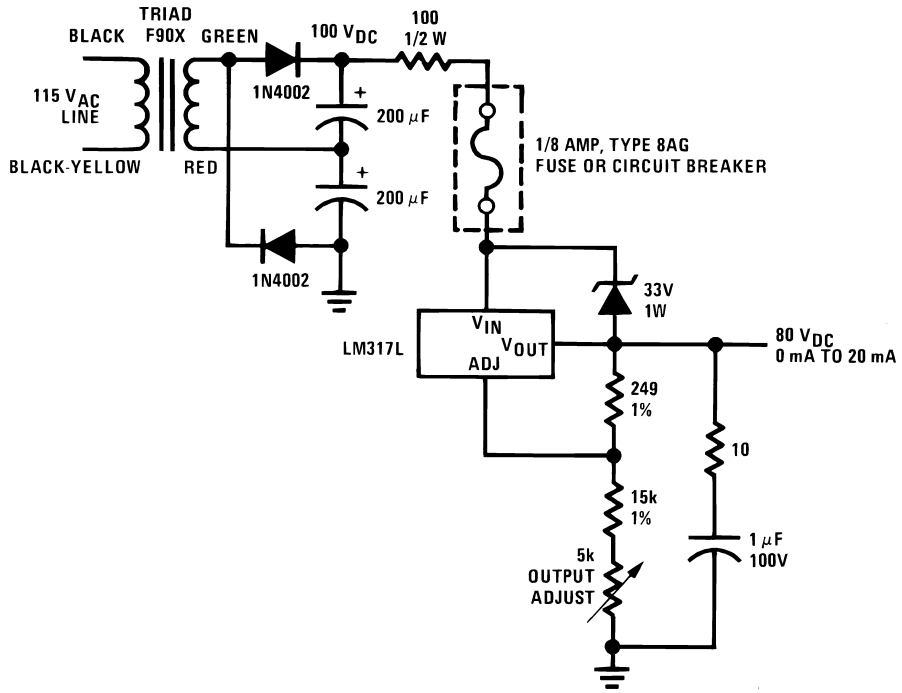

DS009064-28

Basic High Voltage Regulator

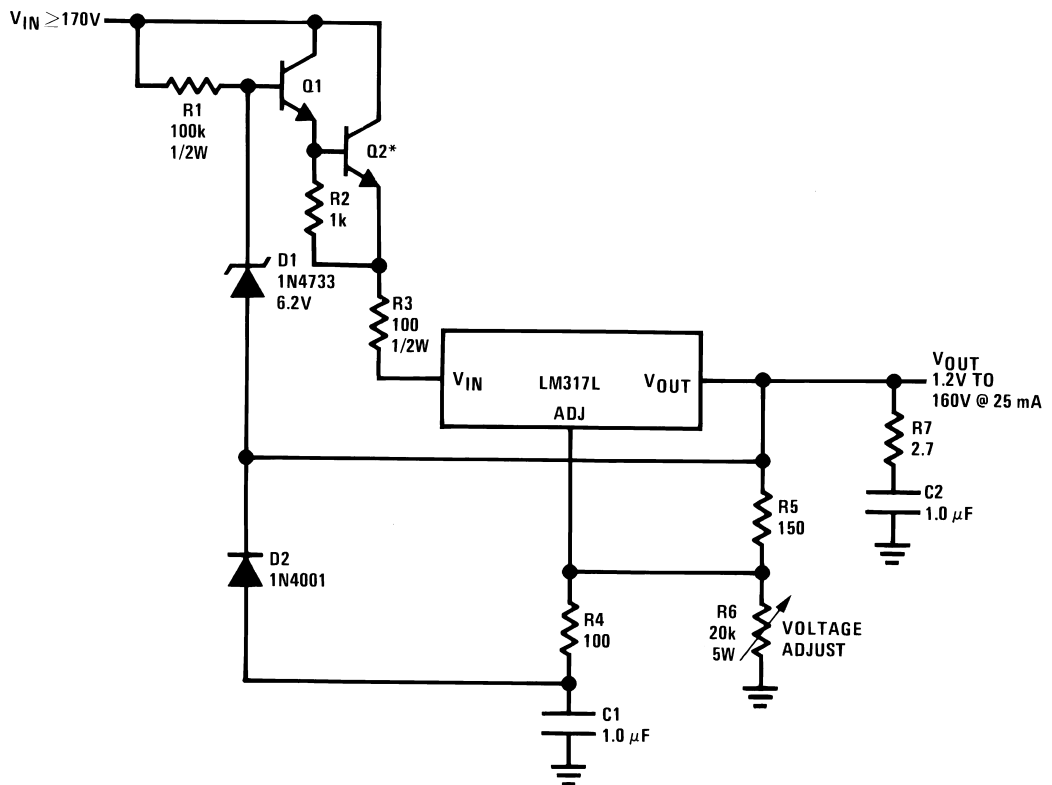

DS009064-29

Q1, Q2: NSD134 or similar
 C1, C2: 1μF, 200V mylar**
 *Heat sink

Typical Applications (Continued)

Precision High Voltage Regulator

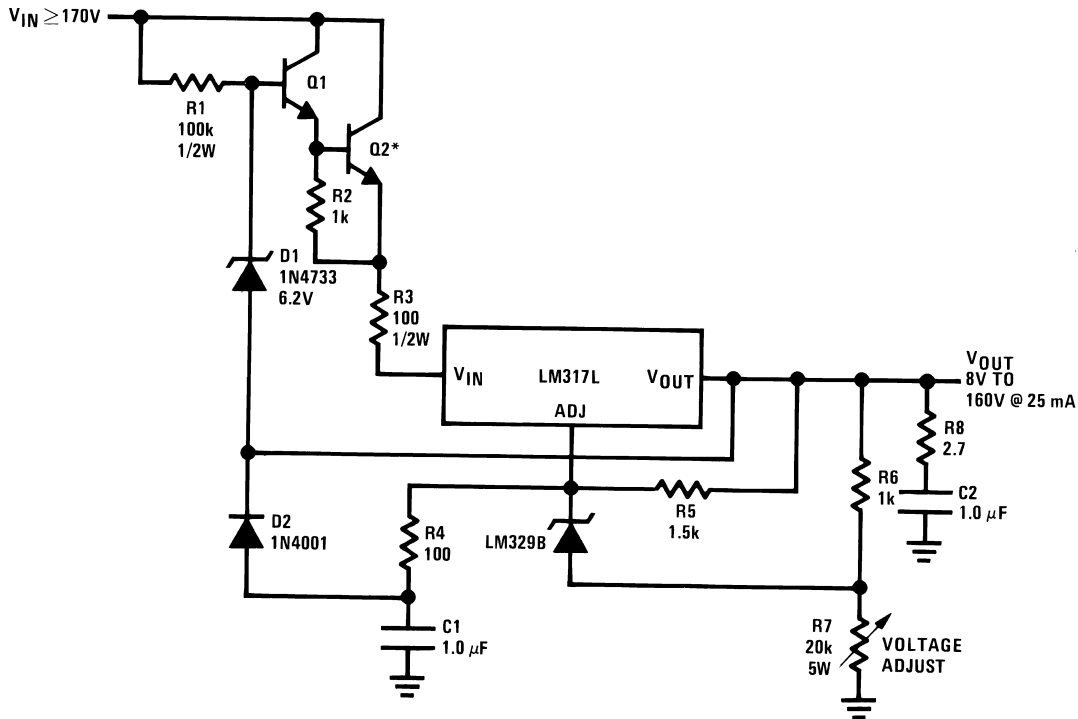

DS009064-30

Q1, Q2: NSD134 or similar
C1, C2: 1μF, 200V mylar**

*Heat sink

**Mylar is a registered trademark of DuPont Co.

Tracking Regulator

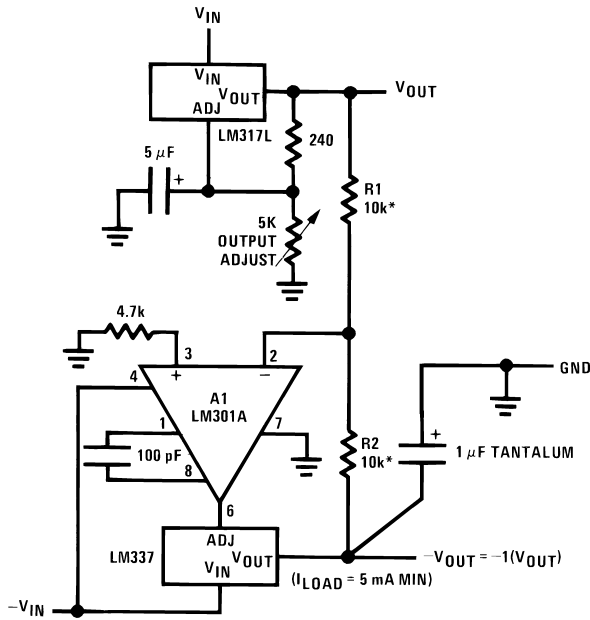

DS009064-31

A1 = LM301A, LM307, or LF13741 only

R1, R2 = matched resistors with good TC tracking

Regulator With Trimmable Output Voltage

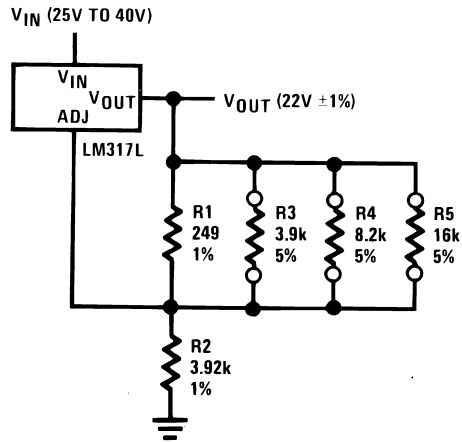

DS009064-32

Trim Procedure:

- If V_{OUT} is 23.08V or higher, cut out R3 (if lower, don't cut it out).
- Then if V_{OUT} is 22.47V or higher, cut out R4 (if lower, don't).
- Then if V_{OUT} is 22.16V or higher, cut out R5 (if lower, don't).

This will trim the output to well within $\pm 1\%$ of $22.00 V_{DC}$, without any of the expense or uncertainty of a trim pot (see LB-46). Of course, this technique can be used at any output voltage level.

Typical Applications (Continued)

Precision Reference with Short-Circuit Proof Output

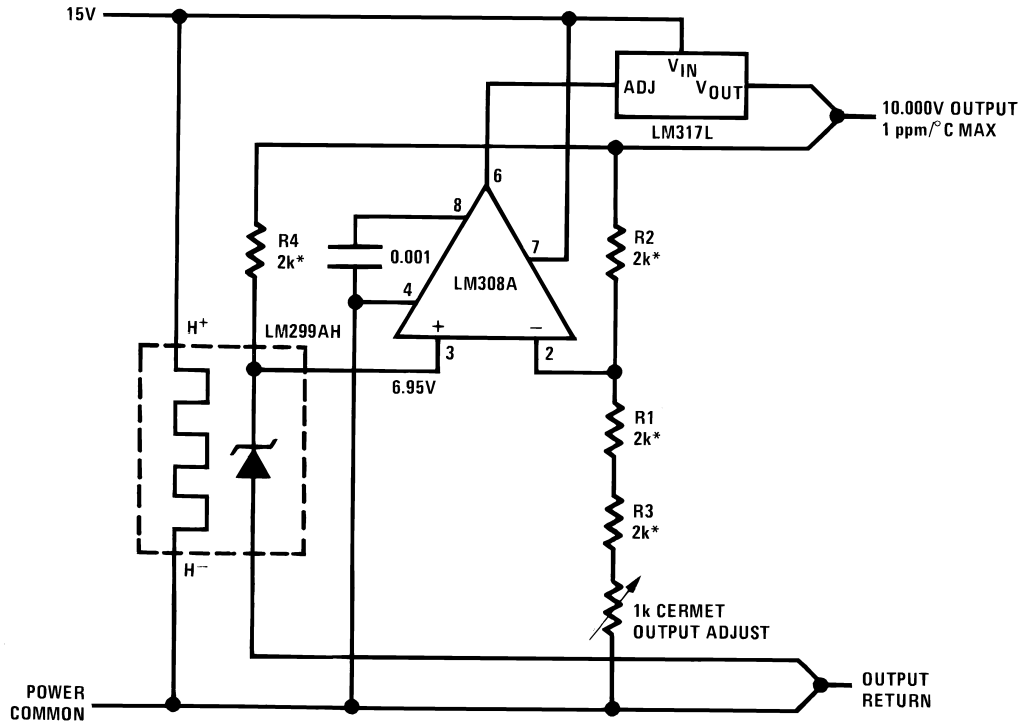

DS009064-33

*R1–R4 from thin-film network, Beckman 694-3-R2K-D or similar

1.2V-25 Adjustable Regulator

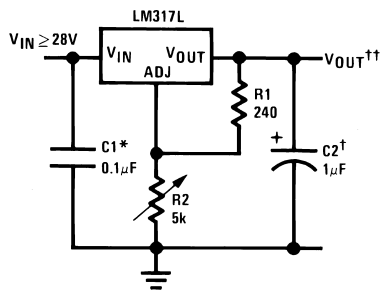

DS009064-1

Full output current not available at high input-output voltages
 †Optional — improves transient response
 *Needed if device is more than 6 inches from filter capacitors

$$\dagger\dagger V_{OUT} = 1.25V \left(1 + \frac{R_2}{R_1} \right) + I_{ADJ} (R_2)$$

Fully Protected (Bulletproof) Lamp Driver

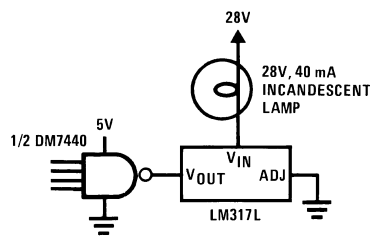

DS009064-2

Lamp Flasher

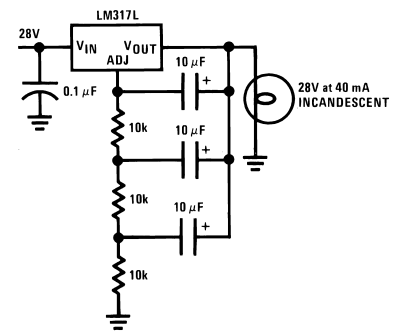

DS009064-3

Output rate — 4 flashes per second at 10% duty cycle

Physical Dimensions inches (millimeters) unless otherwise noted

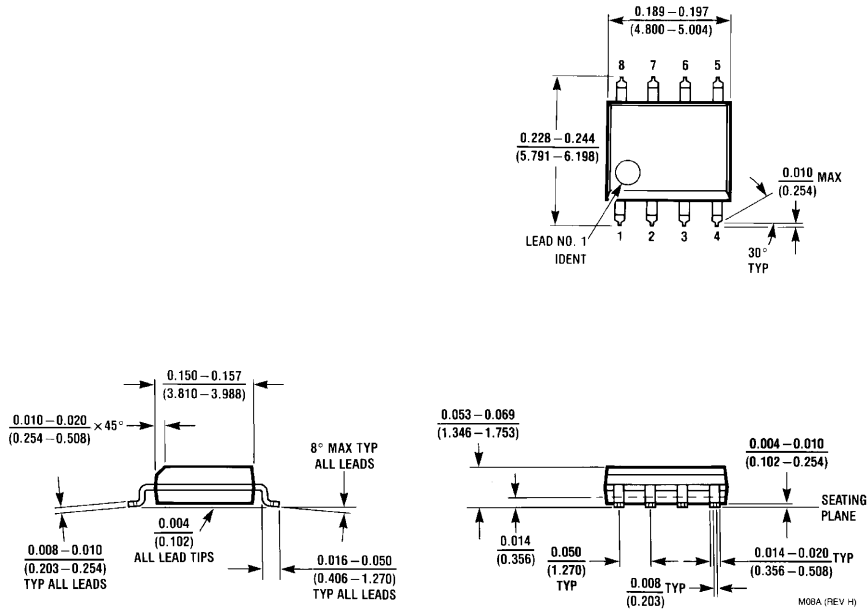

SO-8 Molded Package
NS Package Number M08A

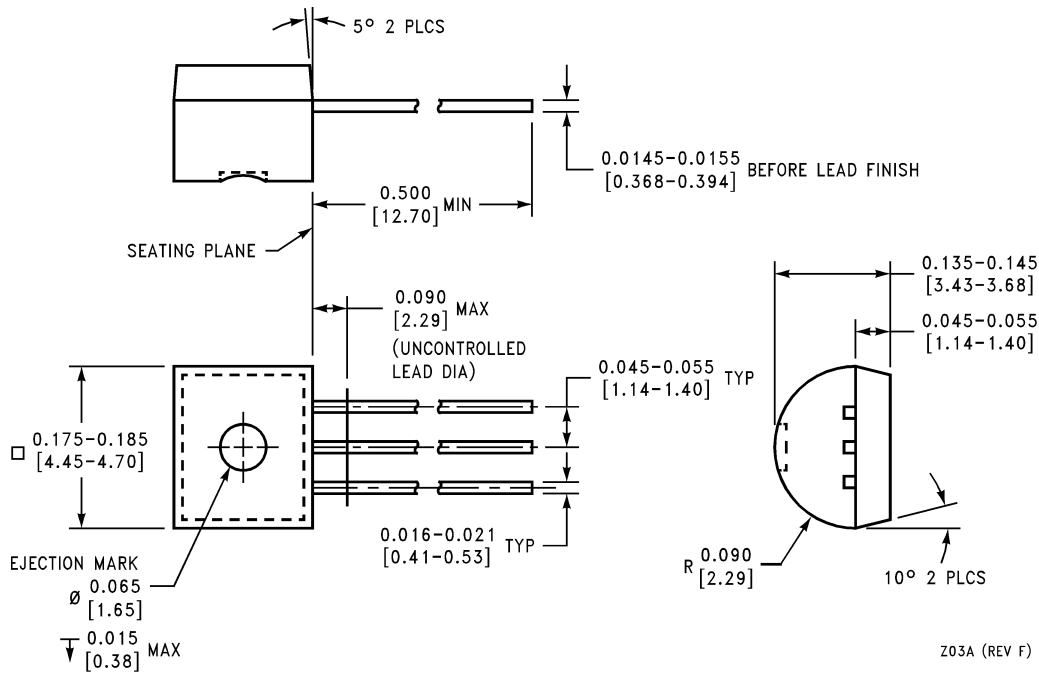

TO-92 Plastic Package (Z)
NS Package Number Z03A

Physical Dimensions inches (millimeters) unless otherwise noted (Continued)

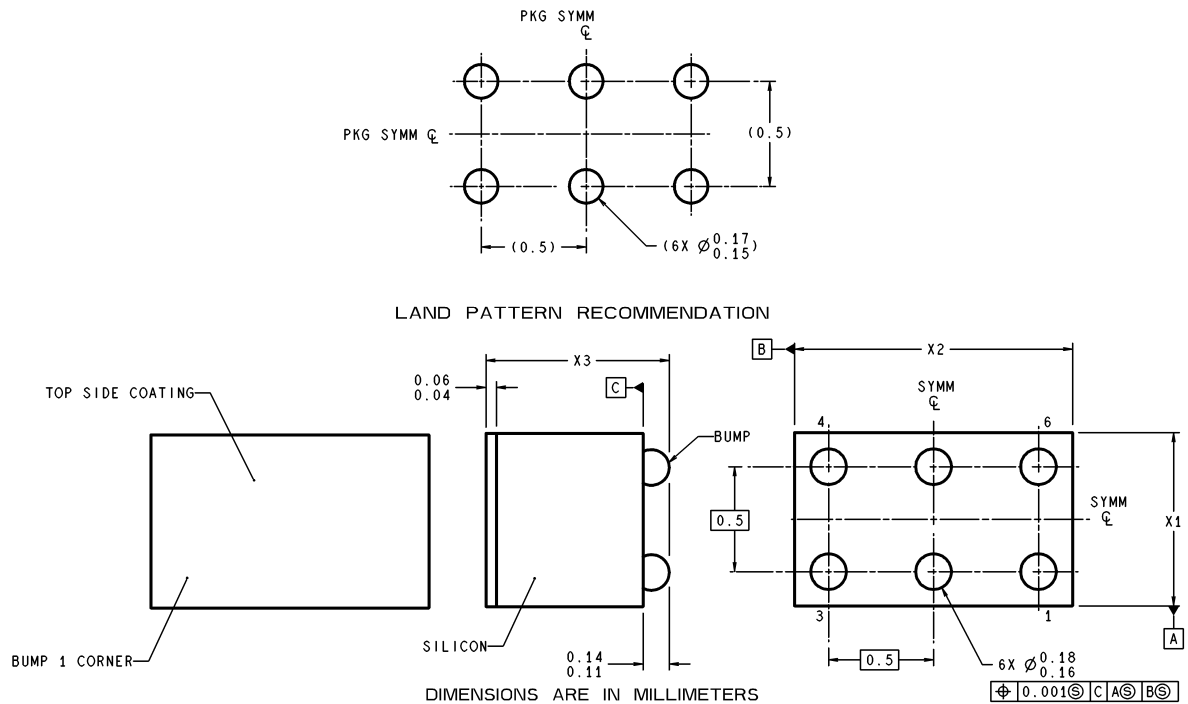

BPA06XXX (Rev A)

NOTE: UNLESS OTHERWISE SPECIFIED.

1. EPOXY COATING
2. 63Sn/37Pb EUTECTIC BUMP.
3. RECOMMEND NON-SOLDER MASK DEFINED LANDING PAD.
4. PIN 1 IS ESTABLISHED BY LOWER LEFT CORNER WITH RESPECT TO TEXT ORIENTATION PINS ARE NUMBERED COUNTERCLOCKWISE.
5. XXX IN DRAWING NUMBER REPRESENTS PACKAGE SIZE VARIATION WHERE X_1 IS PACKAGE WIDTH, X_2 IS PACKAGE LENGTH AND X_3 IS PACKAGE HEIGHT.
6. REFERENCE JEDEC REGISTRATION MO-211, VARIATION BC.

6-Bump micro SMD
NS Package Number BPA06HPA
 $X_1 = 0.955$ $X_2 = 1.615$ $X_3 = 0.700$

Notes

LIFE SUPPORT POLICY

NATIONAL'S PRODUCTS ARE NOT AUTHORIZED FOR USE AS CRITICAL COMPONENTS IN LIFE SUPPORT DEVICES OR SYSTEMS WITHOUT THE EXPRESS WRITTEN APPROVAL OF THE PRESIDENT AND GENERAL COUNSEL OF NATIONAL SEMICONDUCTOR CORPORATION. As used herein:

1. Life support devices or systems are devices or systems which, (a) are intended for surgical implant into the body, or (b) support or sustain life, and whose failure to perform when properly used in accordance with instructions for use provided in the labeling, can be reasonably expected to result in a significant injury to the user.
2. A critical component is any component of a life support device or system whose failure to perform can be reasonably expected to cause the failure of the life support device or system, or to affect its safety or effectiveness.



National Semiconductor Corporation
Americas
Tel: 1-800-272-9959
Fax: 1-800-737-7018
Email: support@nsc.com
www.national.com

National Semiconductor Europe
Fax: +49 (0) 180-530 85 86
Email: europe.support@nsc.com
Deutsch Tel: +49 (0) 69 9508 6208
English Tel: +44 (0) 870 24 0 2171
Français Tel: +33 (0) 1 41 91 8790

National Semiconductor Asia Pacific Customer Response Group
Tel: 65-2544466
Fax: 65-2504466
Email: ap.support@nsc.com

National Semiconductor Japan Ltd.
Tel: 81-3-5639-7560
Fax: 81-3-5639-7507